

MAXIM

USB-Powered Li+ Charger

MAX1811

General Description

The MAX1811 is a single-cell lithium-ion (Li+) battery charger that can be powered directly from a USB port* or from an external supply up to 6.5V. It has a 0.5% overall battery regulation voltage accuracy to allow maximum utilization of the battery capacity.

The charger uses an internal FET to deliver up to 500mA charging current to the battery. The device can be configured for either a 4.1V or 4.2V battery, using the SELV input. The SELI input sets the charge current to either 100mA or 500mA. An open-drain output (CHG) indicates charge status.

The MAX1811 has preconditioning that soft-starts a near-dead battery cell before charging. Other safety features include continuous monitoring of voltage and current and initial checking for fault conditions before charging.

The MAX1811 is available in a small 1.4W thermally enhanced 8-pin SO package.

Features

- ◆ Charges Single-Cell Li+ Batteries Directly from USB Port
- ◆ 0.5% Overall Charging Accuracy
- ◆ Minimal External Components
- ◆ Input Diode Not Required
- ◆ Automatic IC Thermal Regulation
- ◆ Preconditions Near-Depleted Cells
- ◆ Convenient Power SO-8 Package (1.4W)
- ◆ Protected by U.S. Patent # 6,507,172

Applications

- PDA's and Palmtops
- Digital Still Cameras
- MP3 Players
- Cell Phones
- Two-Way Pagers
- Hand-Held Computers

Ordering Information

PART	TEMP RANGE	PIN-PACKAGE
MAX1811ESA	-40°C to +85°C	8 SO

Typical Operating Circuit

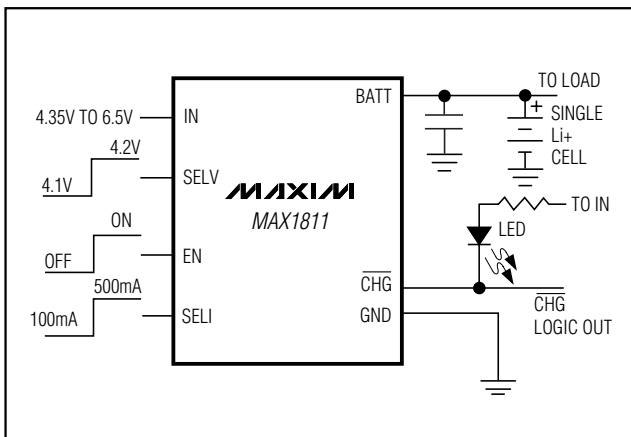

Pin Configuration

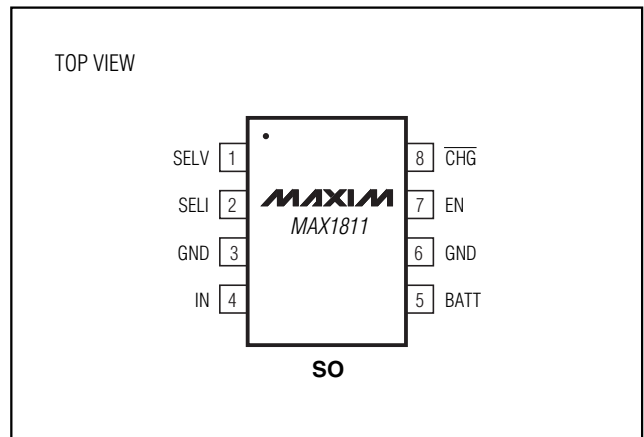

* Protected by U.S. Patent # 6,507,172

USB-Powered Li+ Charger

ABSOLUTE MAXIMUM RATINGS

IN, BATT, SELI, $\overline{\text{CHG}}$, EN to GND	-0.3V to 7V	Operating Temperature Range	-40°C to +85°C
SELV to GND	-0.3V to ($V_{\text{IN}} + 0.3\text{V}$)	Storage Temperature Range	-65°C to +150°C
Continuous Power Dissipation ($T_{\text{A}} = +70^{\circ}\text{C}$)		Maximum Die Temperature	+150°C
8-Pin SO (derate 17.5mW/°C above +70°C)	1.4W	Lead Temperature (soldering, 10s)	+300°C
Short-Circuit Duration	Continuous		

Stresses beyond those listed under "Absolute Maximum Ratings" may cause permanent damage to the device. These are stress ratings only, and functional operation of the device at these or any other conditions beyond those indicated in the operational sections of the specifications is not implied. Exposure to absolute maximum rating conditions for extended periods may affect device reliability.

ELECTRICAL CHARACTERISTICS

($V_{\text{IN}} = 4.5\text{V}$, EN = IN, $T_{\text{A}} = 0^{\circ}\text{C}$ to +85°C, unless otherwise noted.)

PARAMETER	CONDITIONS	MIN	TYP	MAX	UNITS
Input Supply Voltage		4.35		6.50	V
Input Undervoltage Lockout	I_{IN} rising	3.75		4.05	V
Input Undervoltage Lockout Hysteresis			50		mV
Input Supply Current	Operating, EN = IN, no load		0.9	2.0	mA
	Shutdown, EN = GND		2.5	5.0	μA
Charging Headroom	SELI = GND (100mA mode), $V_{\text{IN}} = 4.35\text{V}$		100		mV
	SELI = IN (500mA mode)		200		
Precondition Threshold	BATT rising, transition from precondition to charge mode	2.3	2.5	2.7	V
Precondition Threshold Hysteresis			80		mV
$\overline{\text{CHG}}$ Output Leakage Current	$V_{\text{IN}} = V_{\overline{\text{CHG}}} = 6.5\text{V}$		0.1	1.0	μA
$\overline{\text{CHG}}$ Output Low Voltage	$I_{\text{SINK}} = 10\text{mA}$			0.4	V
Charging Current	$V_{\text{SELI}} = V_{\text{IN}} = 5.5\text{V}$, $V_{\text{BATT}} = 2.7\text{V}$		455	500	mA
	SELI = GND, $V_{\text{IN}} = 5.5\text{V}$, $V_{\text{BATT}} = 2.7\text{V}$		85	100	
	$V_{\text{BATT}} = 2\text{V}$, SELI = GND or IN	20	43	70	
BATT Regulation Voltage	SELV = GND, $I_{\text{BATT}} = 0$	4.08	4.10	4.12	V
	SELV = IN, $I_{\text{BATT}} = 0$	4.18	4.20	4.22	
BATT Leakage Current (Input Power Removed)	$V_{\text{BATT}} = 4.2\text{V}$, EN = IN = GND		1	5	μA
BATT Shutdown Current	EN = GND, $V_{\text{BATT}} = 4.2\text{V}$		0.1	2	μA
Logic Input Low Voltage (EN, SELI, SELV)	$V_{\text{IN}} = 4.35\text{V}$ to 6.5V			0.8	V
Logic Input High Voltage (EN, SELI, SELV)	$V_{\text{IN}} = 4.35\text{V}$ to 6.5V	2.0			V
Logic Input Leakage Current (EN, SELI)	$V_{\text{IN}} = 0$ to 6.5V; V_{SELI} , $V_{\text{EN}} = 6.5\text{V}$ or GND			1	μA
Logic Input Leakage Current (SELV)	$V_{\text{IN}} = 0$ to 6.5V, $V_{\text{SELV}} = V_{\text{IN}}$ or GND			1	μA
Thermal Regulation	Die temperature beyond which charging current is reduced		125		$^{\circ}\text{C}$

USB-Powered Li+ Charger

MAX1811

ELECTRICAL CHARACTERISTICS

($V_{IN} = 4.5V$, $T_A = -40^{\circ}C$ to $+85^{\circ}C$, unless otherwise noted.) (Note1)

PARAMETER	CONDITIONS	MIN	TYP	MAX	UNITS
Input Supply Voltage		4.35		6.50	V
Input Undervoltage Lockout	I_{IN} rising	3.75		4.05	V
Input Supply Current	Operating, $EN = IN$, no load			3	mA
	Shutdown, $EN = GND$			6	μA
Precondition Threshold	BATT rising, transition from precondition to charge mode	2.3		2.7	V
BATT Regulation Voltage	$SELV = GND$, $I_{BATT} = 0$	4.06		4.14	V
	$SELV = IN$, $I_{BATT} = 0$	4.16		4.24	
BATT Leakage Current (Input Power Removed)	$V_{BATT} = 4.2V$, $IN = GND$			10	μA
BATT Shutdown Current	$EN = GND$, $V_{BATT} = 4.2V$			3	μA

Note 1: Specifications to $-40^{\circ}C$ are guaranteed by design and not production tested.

Typical Operating Characteristics

(CHG unconnected, $C_{BATT} = 2.2\mu F$, $T_A = +25^{\circ}C$, unless otherwise noted.)

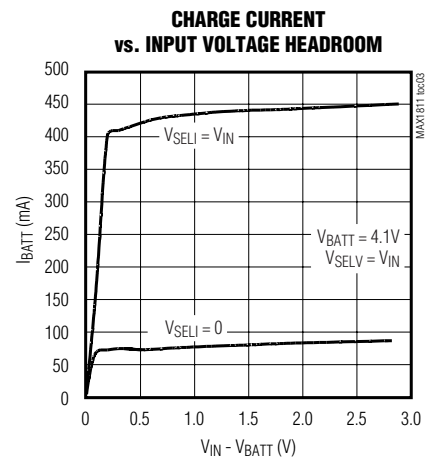
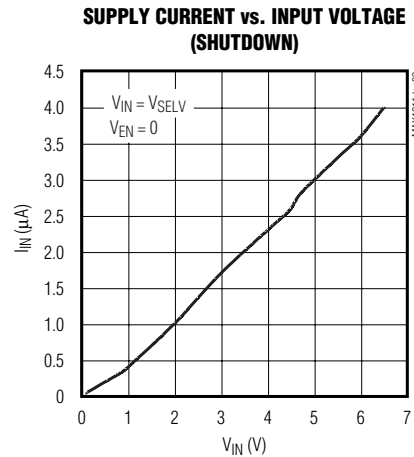
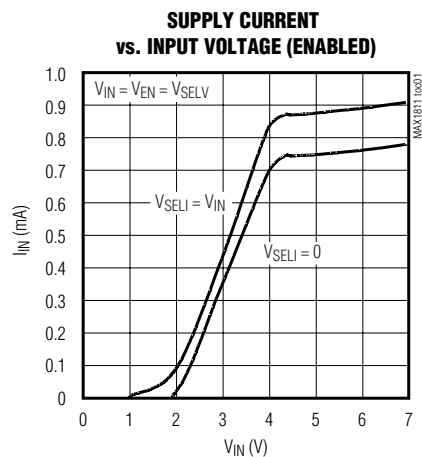

USB-Powered Li+ Charger

Typical Operating Characteristics (continued)

(CHG unconnected, $C_{BATT} = 2.2\mu F$, $T_A = +25^\circ C$, unless otherwise noted.)

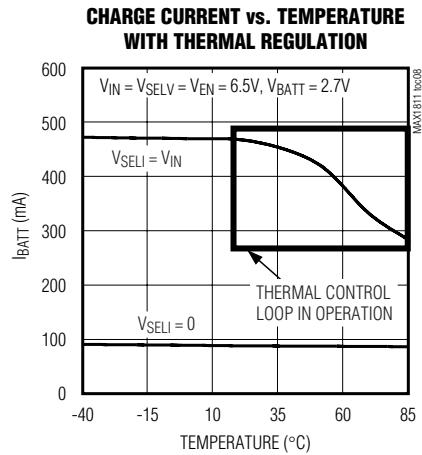
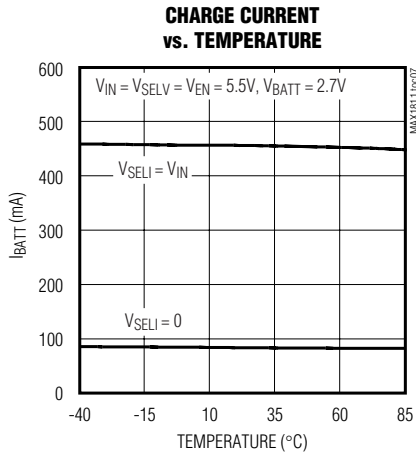
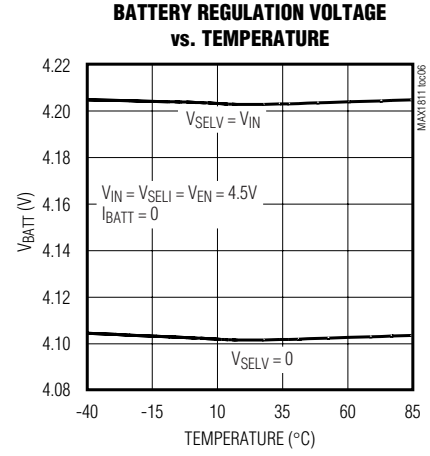
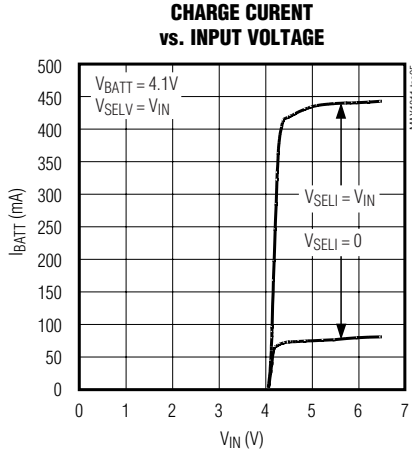
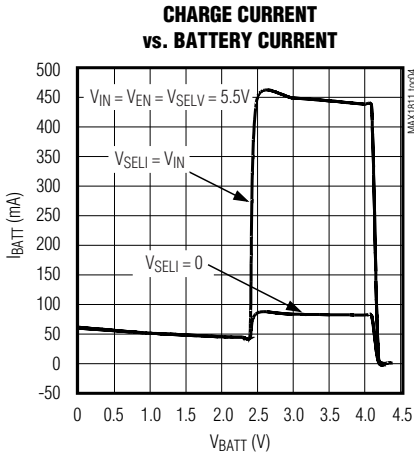

USB-Powered Li+ Charger

MAX1811

Pin Description

PIN	NAME	DESCRIPTION
1	SELV	Battery Regulation Voltage-Select Input. A low (< 0.8V) selects a 4.1V battery regulation set point. A high (> 2.0V) selects a 4.2V battery regulation set point.
2	SELI	Battery Regulation Current-Select Input. A low (< 0.8V) selects a 100mA maximum battery regulation current. A high (> 2.0V) selects a 500mA maximum battery regulation current. SELI is not diode clamped to IN, and the voltage at V _{SELI} can exceed the voltage at V _{IN} .
3, 6	GND	Ground. Connect pins 3 and 6 to a large copper trace for maximum power dissipation.
4	IN	Input Supply Voltage. Bypass with a 4.7μF capacitor to GND.
5	BATT	Li+ Battery Connection. Bypass with a capacitor no less than 2.2μF to GND. High impedance in shutdown.
7	EN	Enable Input. A high (> 2.0V) enables the device. A low (< 0.8V) disables the device and places it into shutdown mode. BATT is high impedance when disabled.
8	CHG	Charging Indicator Open-Drain Output. $\overline{\text{CHG}}$ pulls low while the device is in charge mode (2.5V < V _{BATT} < BATT Regulation Voltage).

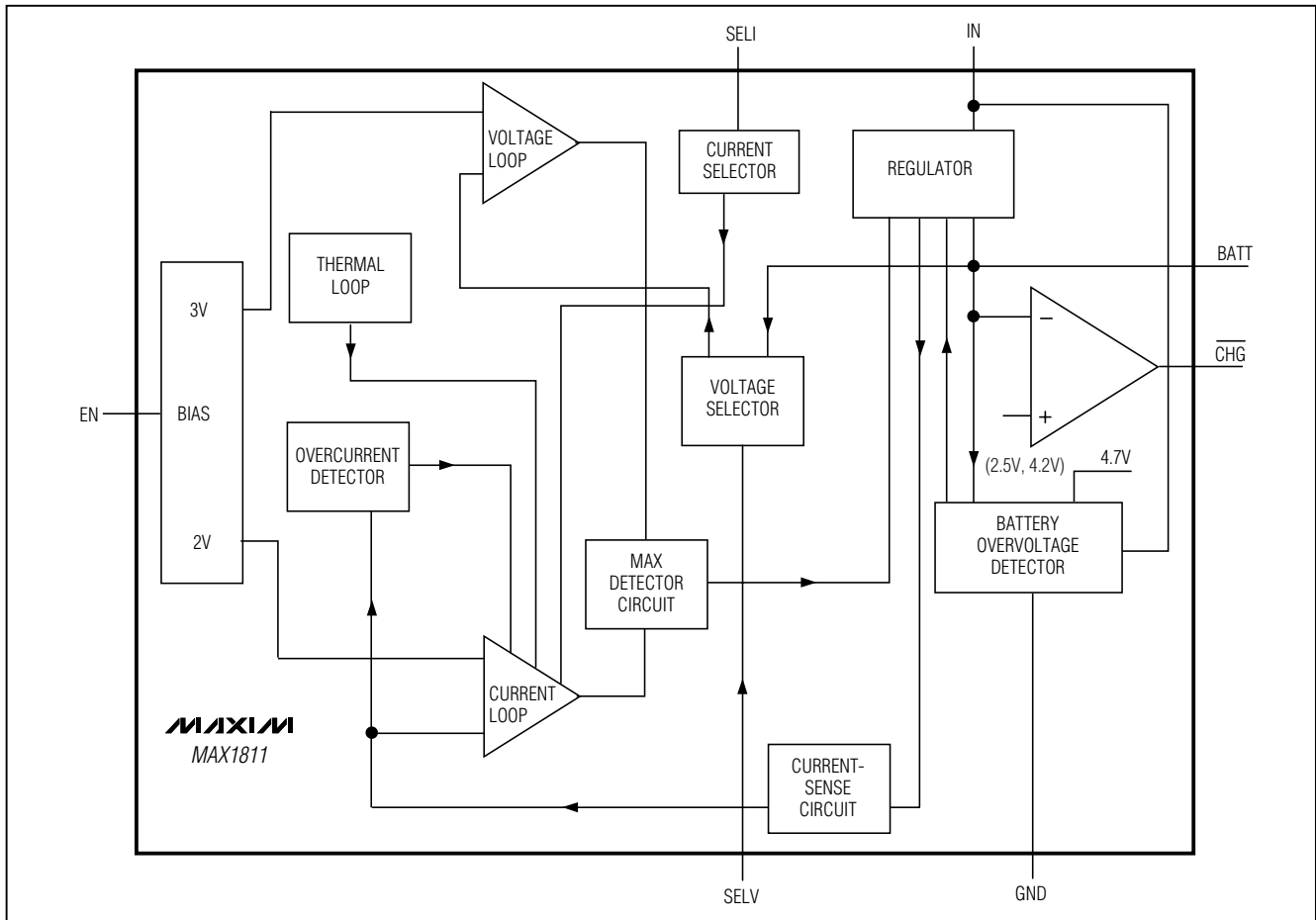

Figure 1. Functional Diagram

USB-Powered Li+ Charger

Detailed Description

Charger-Control Circuitry

The voltage/current regulator consists of a voltage control loop, a current control loop, and a thermal control loop (Figure 1). Use the SELV input to set the battery regulation voltage to a 4.1V or 4.2V single Li+ cell. The current and thermal loops are internally compensated and require no external compensation. The outputs from all loops drive an internal linear regulator. The thermal loop modulates the current loop by limiting the charge current if the die temperature exceeds +125°C. The MAX1811 is in current mode when the BATT voltage is below the regulation set point and in voltage mode when the BATT voltage is near the regulation set point. The $\overline{\text{CHG}}$ output indicates whether the part is in current mode ($\overline{\text{CHG}}$ = low) or voltage mode ($\overline{\text{CHG}}$ = high impedance). Battery voltages less than 2.5V activate a 43mA preconditioning mode ($\overline{\text{CHG}}$ = high impedance). Normal charging resumes when the battery voltage exceeds 2.5V.

System Configuration

The MAX1811 is designed to operate seamlessly with a universal serial bus (USB) port. In a typical design, the USB connects to the MAX1811 input, and the MAX1811 drives the load and charges the battery when enabled.

Charge-Current Selection

The MAX1811 charges a single cell Li+ battery in either 100mA or 500mA modes. The MAX1811 expects the system to poll the USB host to determine if the USB is capable of providing 100mA or 500mA and regulates the charging current accordingly (Figure 2). This is to maintain compatibility with both powered and unpowered USB hosts. A powered USB host is capable of

providing 500mA, and an unpowered USB hub is limited to only 100mA.

Drive SEL1 low to set the charge current to the 100mA mode. Use a 10k Ω pull-down resistor to ground on SEL1, if necessary, to ensure that the MAX1811 defaults to the 100mA mode in the event that no logic signal is present. Drive SEL1 high to increase the charge current to the 500mA mode only if the polled USB port can provide the required current.

Thermal-Control Circuitry

The thermal loop limits the MAX1811 die temperature to +125°C by reducing the charging current as necessary. The MAX1811 can operate normally with the thermal loop active. This is not a fault condition and can be used continuously. The power dissipated by the internal power FET is determined by $(V_{\text{IN}} - V_{\text{BATT}}) \times I_{\text{CHG}}$. The power dissipation rating for the thermally enhanced 8-pin SO package is 1.4W at +50°C ambient (assuming a 1in² PC board radiating area), which is the maximum ambient temperature at which most Li+ battery manufacturers allow charging. The 1.4W power dissipation may never be reached due to the MAX1811's thermal regulation loop.

Applications Information

USB Output Voltage

The minimum voltage to a USB-powered device may be as low as 4.35V when cable and connector drops are considered (Figure 3). The MAX1811 is optimized for operation at these low input voltage levels. USB hubs may also provide as much as 5.5V. At high input voltages (5.5V) and low cell voltages (2.7V), the MAX1811's thermal loop may limit the charge current until the cell voltage rises.

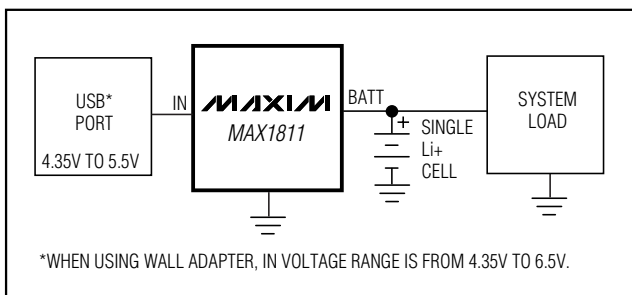

Figure 2. System Configuration

USB-Powered Li+ Charger

MAX1811

Charging from AC Adapters

The MAX1811 also operates from sources other than USB ports. The full charging input voltage range is 4.35V to 6.5V. When charging in the 500mA mode with an AC adapter, rely on the thermal loop to limit the power dissipation by limiting the charge current at higher input voltages if limited PC board area is available to dissipate heat.

Use a larger input bypass capacitor for high input voltages or high charging current to reduce supply noise.

Chip Information

TRANSISTOR COUNT: 1907
PROCESS: BiCMOS

Capacitor Selection

Use a minimum of 2.2 μ F placed close to BATT for proper stability. Bypass IN to GND with a 4.7 μ F capacitor.

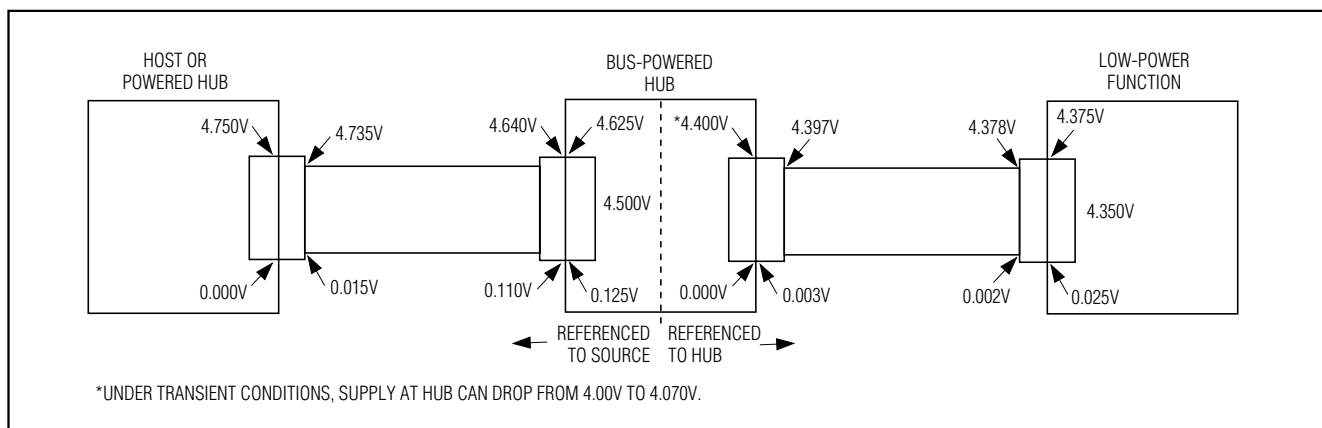

Figure 3. USB Voltage Specification

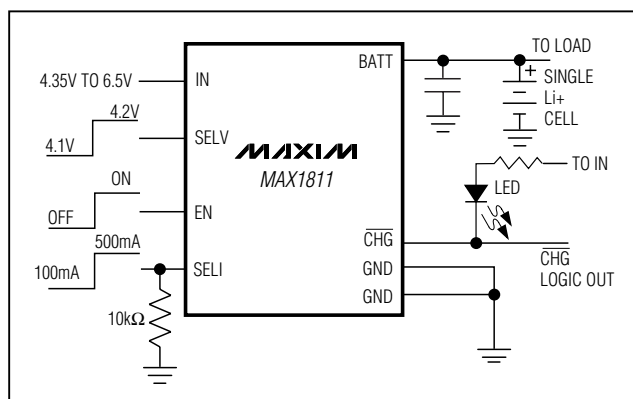
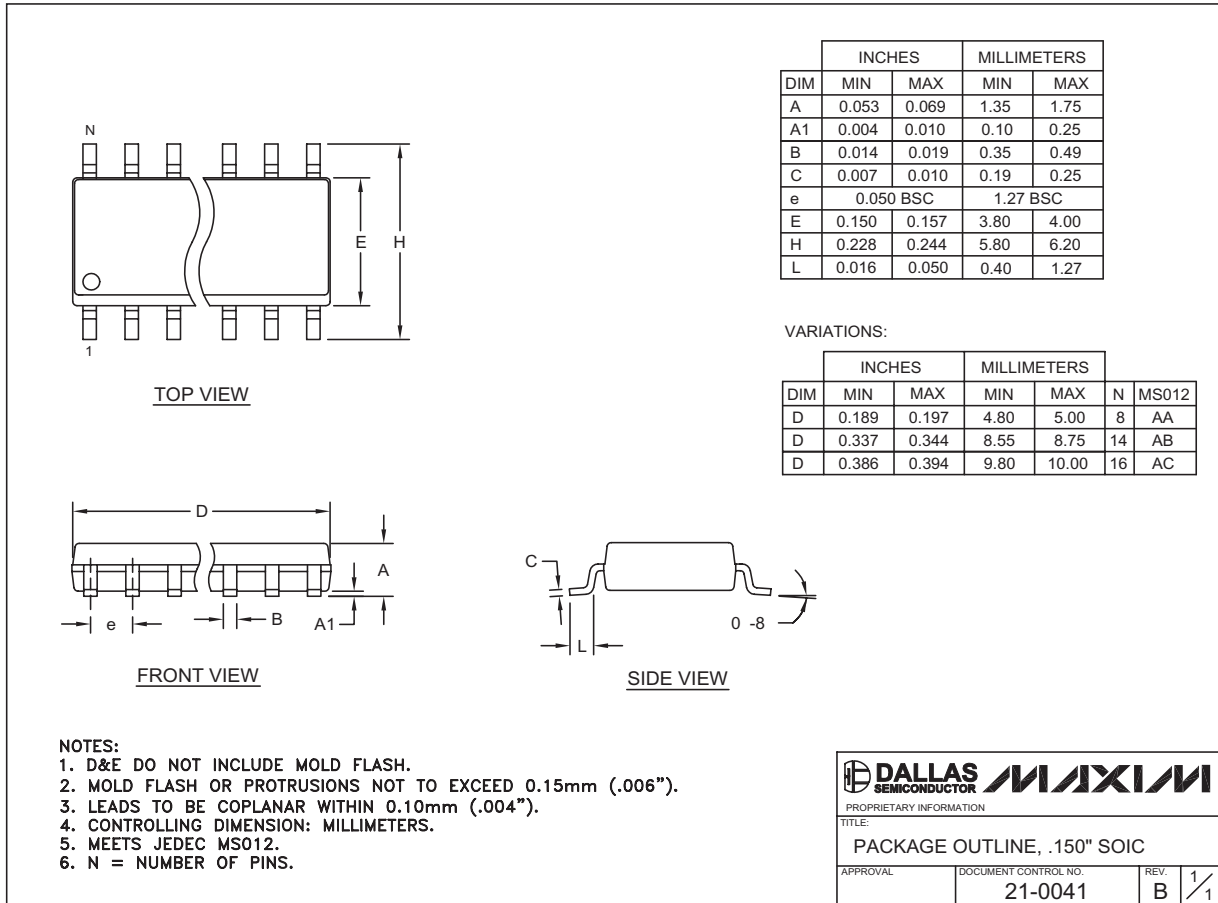

Figure 4. Charging from a USB Port

USB-Powered Li+ Charger

Package Information

(The package drawing(s) in this data sheet may not reflect the most current specifications. For the latest package outline information, go to www.maxim-ic.com/packages.)



SOICN.EPS

Maxim cannot assume responsibility for use of any circuitry other than circuitry entirely embodied in a Maxim product. No circuit patent licenses are implied. Maxim reserves the right to change the circuitry and specifications without notice at any time.

8 **Maxim Integrated Products, 120 San Gabriel Drive, Sunnyvale, CA 94086 408-737-7600**

This datasheet has been download from:

www.datasheetcatalog.com

Datasheets for electronics components.